

DUAL RACK 3 POSITION ACTUATOR OPERATION

REFER TO PLUMBING/CONTROL DIAGRAM FOR A/B PLUMBING SCHEMATICS

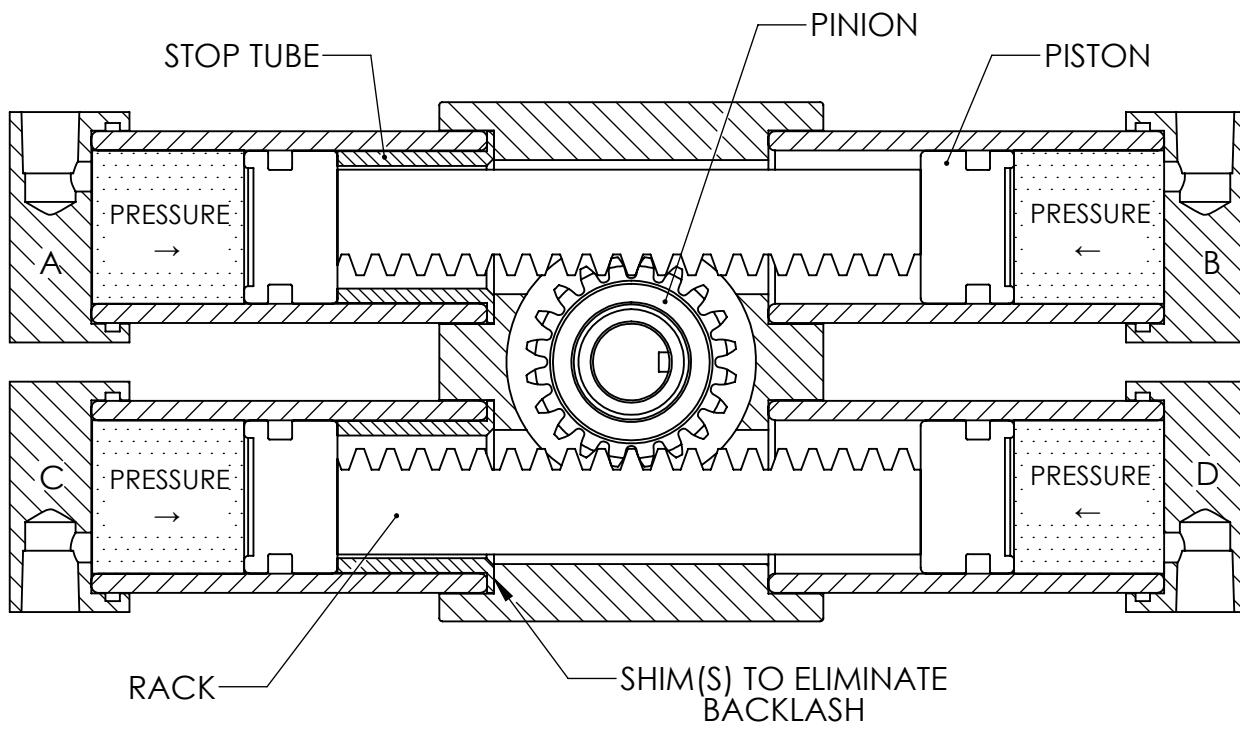

**CENTRAL POSITION
(PLUMBING A)**

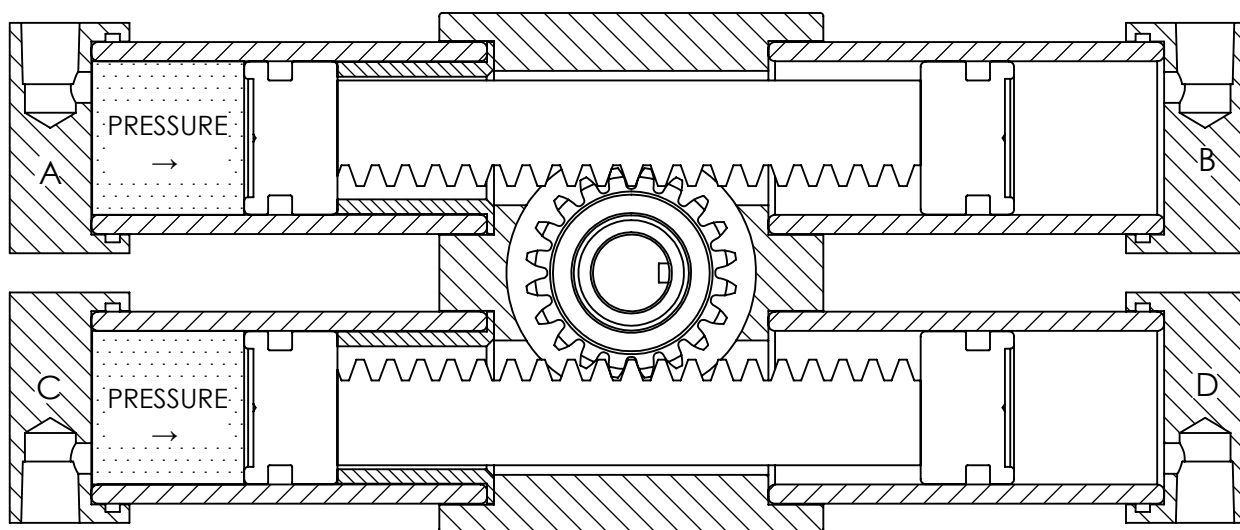

**CENTRAL POSITION
(PLUMBING B)**

NOTE:
ONE PISTON LOSES CONTACT WITH THE RACK
WHEN SHAFT IS ROTATED FULLY CW OR CCW

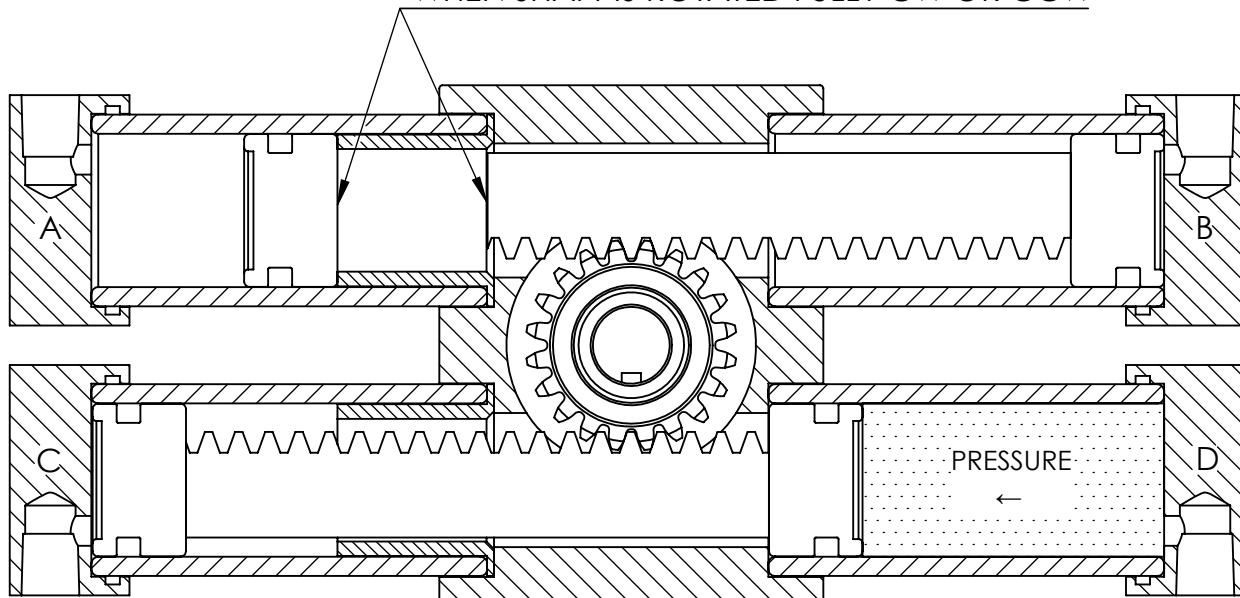

FULLY CW POSITION

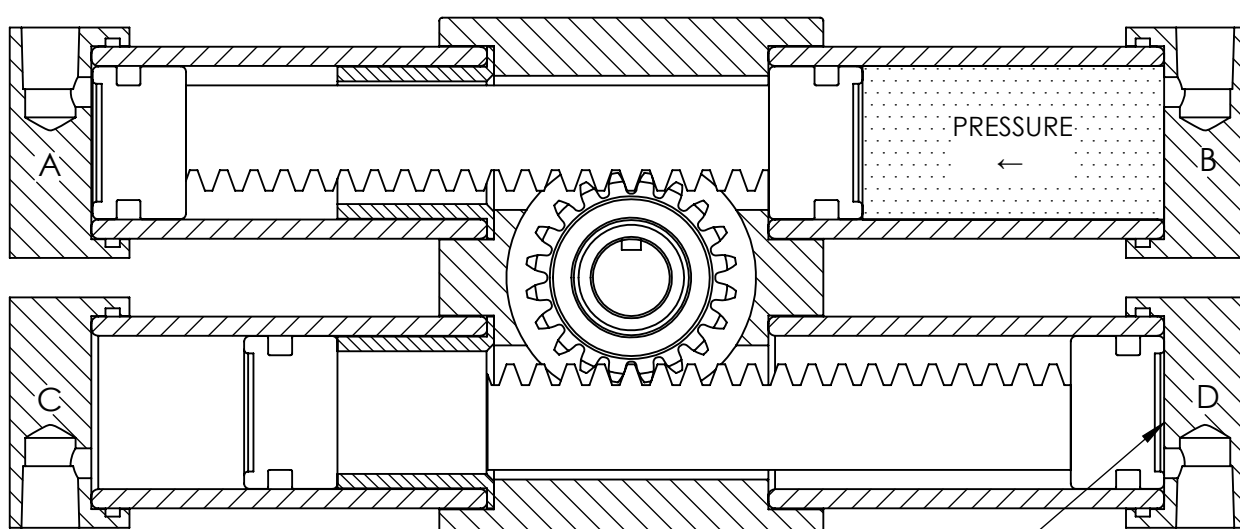

FULLY CCW POSITION

NOTE:
PISTONS BOTTOM OUT ON ENDS 'B' & 'D'
BUT NOT 'A' & 'C' TO TAKE UP BACKLASH