

1

2

3

4

5

6

A

B

C

D

A

B

C

D

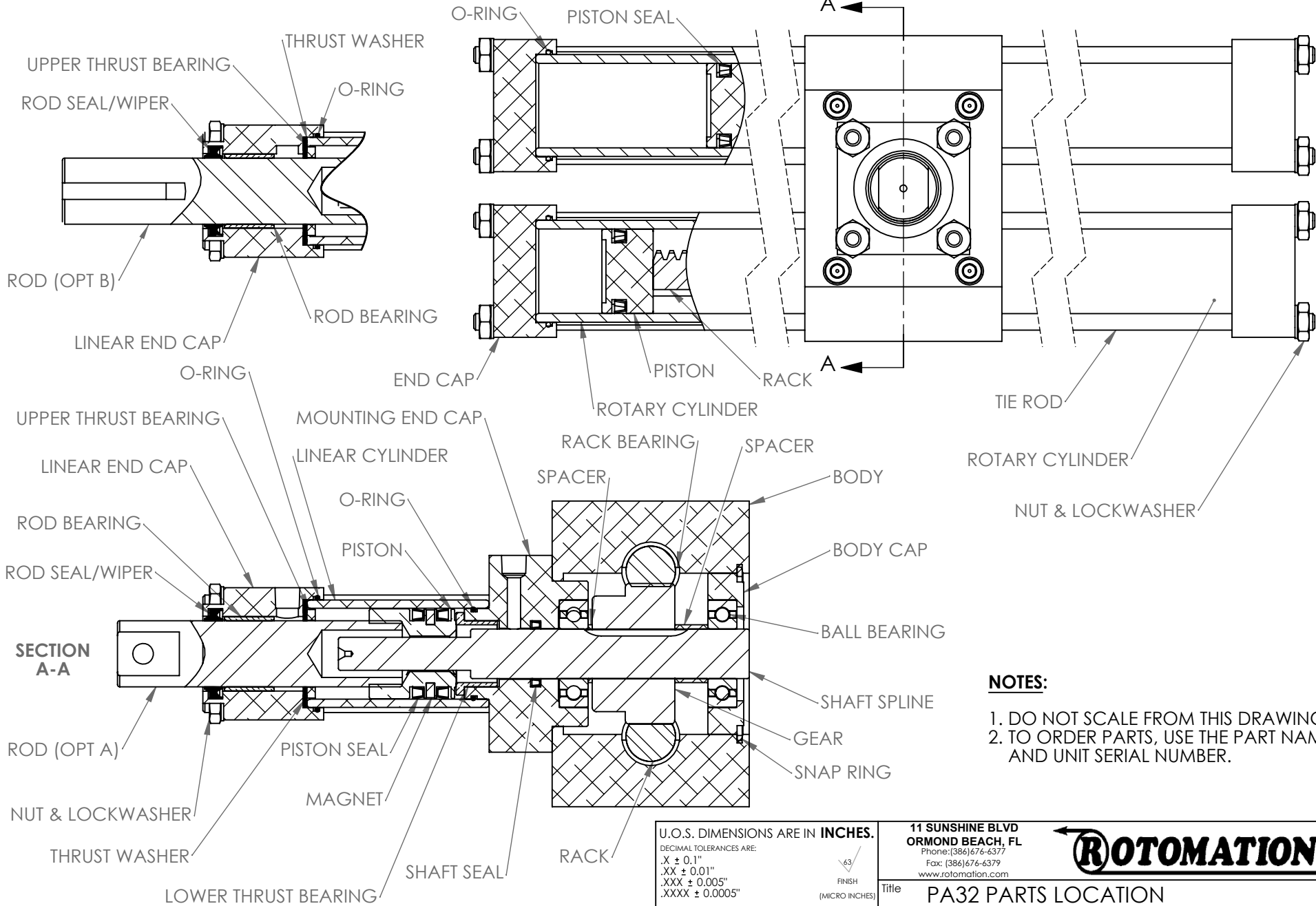

**NOTES:**  
 1. DO NOT SCALE FROM THIS DRAWING.  
 2. TO ORDER PARTS, USE THE PART NAME AND UNIT SERIAL NUMBER.

U.O.S. DIMENSIONS ARE IN INCHES.  
 DECIMAL TOLERANCES ARE:  
 .X ± 0.1"  
 .XX ± 0.01"  
 .XXX ± 0.005"  
 .XXXX ± 0.0005"

11 SUNSHINE BLVD  
 ORMOND BEACH, FL  
 Phone: (386) 676-6377  
 Fax: (386) 676-6379  
 www.rotomation.com



Title: PA32 PARTS LOCATION  
 PICK & PLACE

REV.	DESCRIPTION	DATE	APPROVED
A	UPDATED DRAWING TO INCLUDE NEW PARTS, PER ECO 162	10/11/07	NL
REVISIONS			

MATERIAL  
 ROTOMATION  
 PA3 ACTUATOR

FINISH  
 -

APPROVALS		DATE
DRAWN JMC		10/12/07
CHECKED NL		10/12/07

SIZE	PART NO.	REV
A	PA2-091	-
SCALE	THIRD ANGLE PROJECTION	SHEET
1:2		SHEET 1 OF 1

1

2

3

4

5

6