

'C' DIMENSION		
ROTATION -0/+2 (degrees)	STANDARD (inches)	'G', 'R' OR 'S' OPTION (inches)
30	4.57	6.77
45	5.09	6.97
60	5.62	7.23
90	6.66	7.66
100	7.01	8.01
120	7.71	8.71
180	9.81	10.81
190	10.16	11.16
270	12.95	13.95
360	16.09	17.09
370	16.44	17.44
540	22.37	23.37
550	22.72	23.72
720	28.66	29.66
730	29.00	30.00

OPTIONS: ADD TO 'C' DIM. PER SIDE		
'Q' OPTION	'Q' & 'A' OPTION	'HP', 'A', OR 'K' OPTION
0.06	0.29	0.50

RATINGS	
Torque Factor, Extended (in-lb/psi)	2.79
Torque Factor, Retracted (in-lb/psi)	2.91
Force Factor, Push (lb/psi)	1.48
Force Factor, Pull (lb/psi)	0.70
Bore Diameter (in)	1 3/8
Max. Working Pressure (psi)	250
Backlash @ End of Stroke (degrees)	1.0
Displacement (in ³ /deg.)	0.052
Weight: 180 deg. basic unit (lb)	11.9
Operating Temp. Range (°F):	Basic: 0 to 180 'G', 'R', 'S', or 'Q' OPTION: 0 to 160

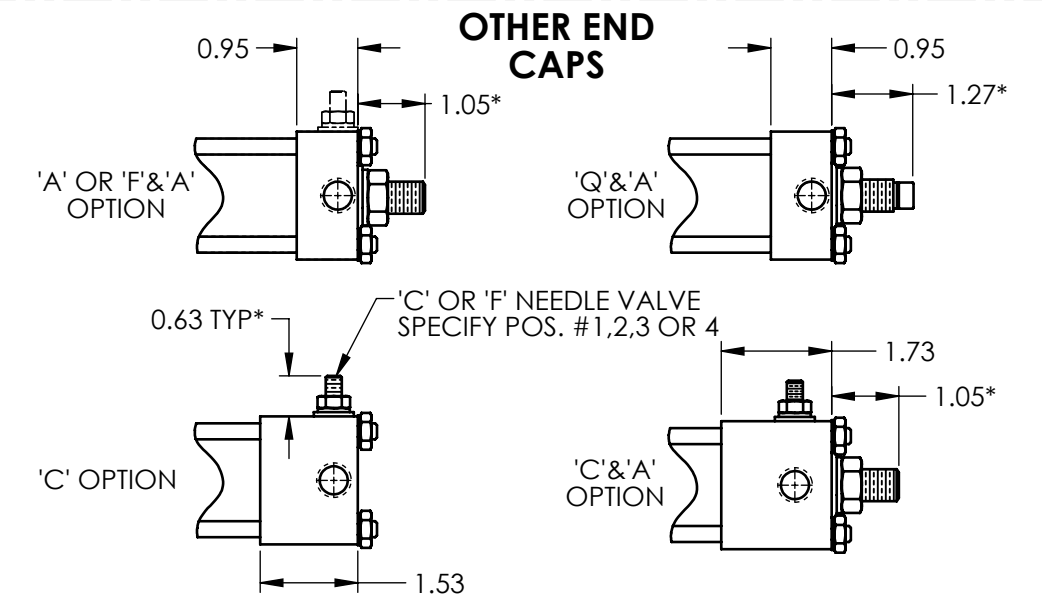



OPTIONAL ROD END (SYMBOL: B)

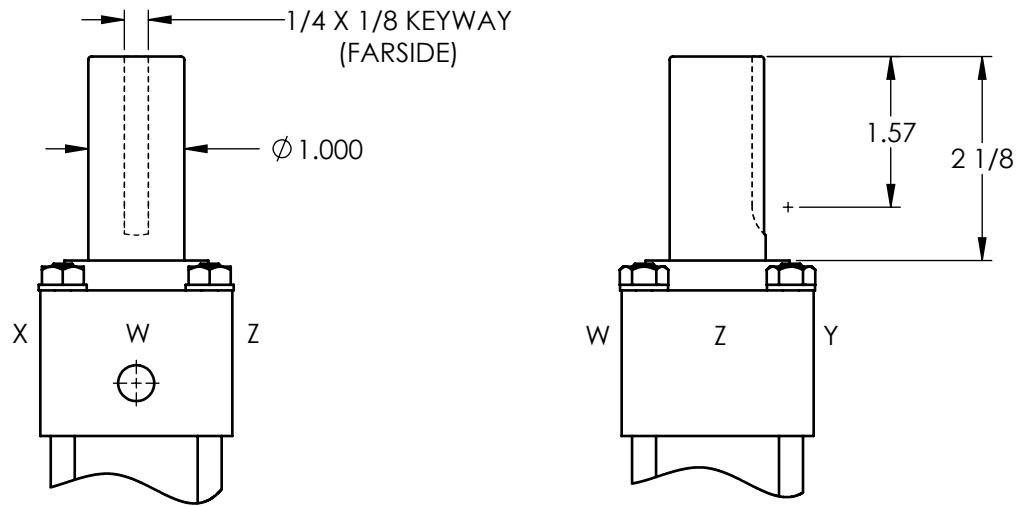

WORKS WITH SMA-10 (SHOWN AT MIDPOINT OF ROTATION)

MOUNTING PLATE OPTIONS (SYMBOL: M OR P)

