

1

2

3

4

5

6

A

A

B

B

C

C

D

D

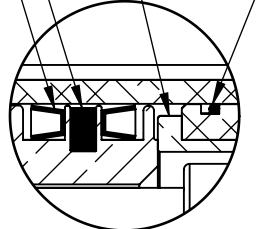
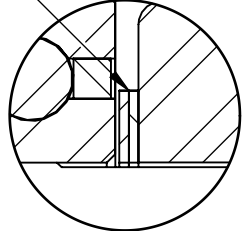
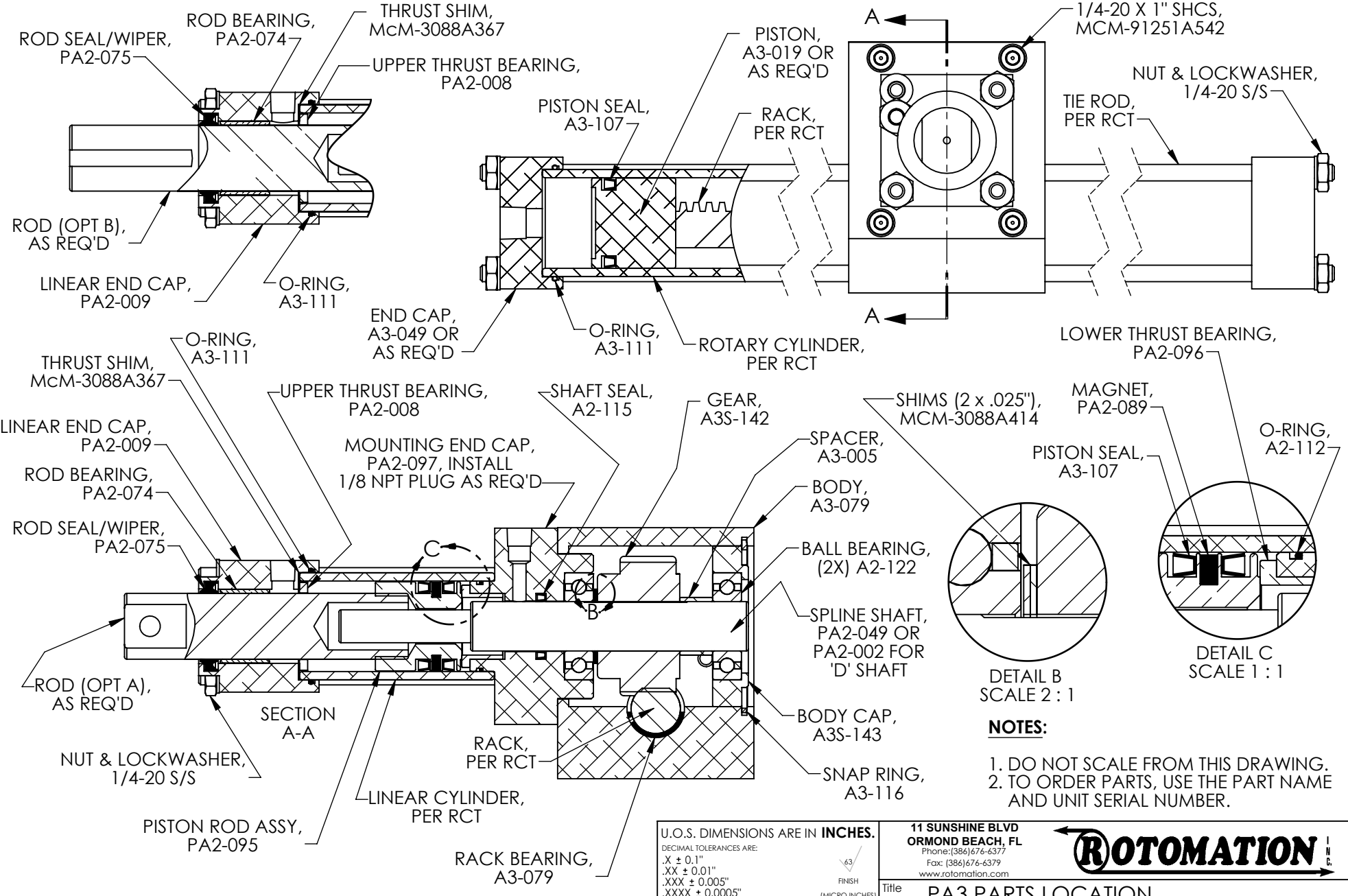

NOTES:

1. DO NOT SCALE FROM THIS DRAWING.
2. TO ORDER PARTS, USE THE PART NAME AND UNIT SERIAL NUMBER.

U.O.S. DIMENSIONS ARE IN INCHES.
 DECIMAL TOLERANCES ARE:
 .X ± 0.1"
 .XX ± 0.01"
 .XXX ± 0.005"
 .XXXX ± 0.0005"
 FINISH
 .63
 (MICRO INCHES)

11 SUNSHINE BLVD
 ORMOND BEACH, FL
 Phone: (386)676-6377
 Fax: (386)676-6379
 www.rotomation.com



REV.	DESCRIPTION	DATE	APPR'D	MATERIAL
B	MODIFIED DRWG. FOR CLARITY, ADDED P/N's AND SPECIFIED STACK SHIMS	11/18/2009	JMC	MATERIAL ROTOMATION
A	UPDATED DRAWING TO INCLUDE NEW PARTS, PER ECO 162	10/11/07	NL	PA3 ACTUATOR
REVISIONS				

APPROVALS		DATE
DRAWN JMC		10/12/07
CHECKED NL		10/12/07

Title PA3 PARTS LOCATION PICK & PLACE		
SIZE A	PART NO. PA2-092	REV B
SCALE 1:2	THIRD ANGLE PROJECTION	SHEET SHEET 1 OF 2

1

2

3

4

5

6

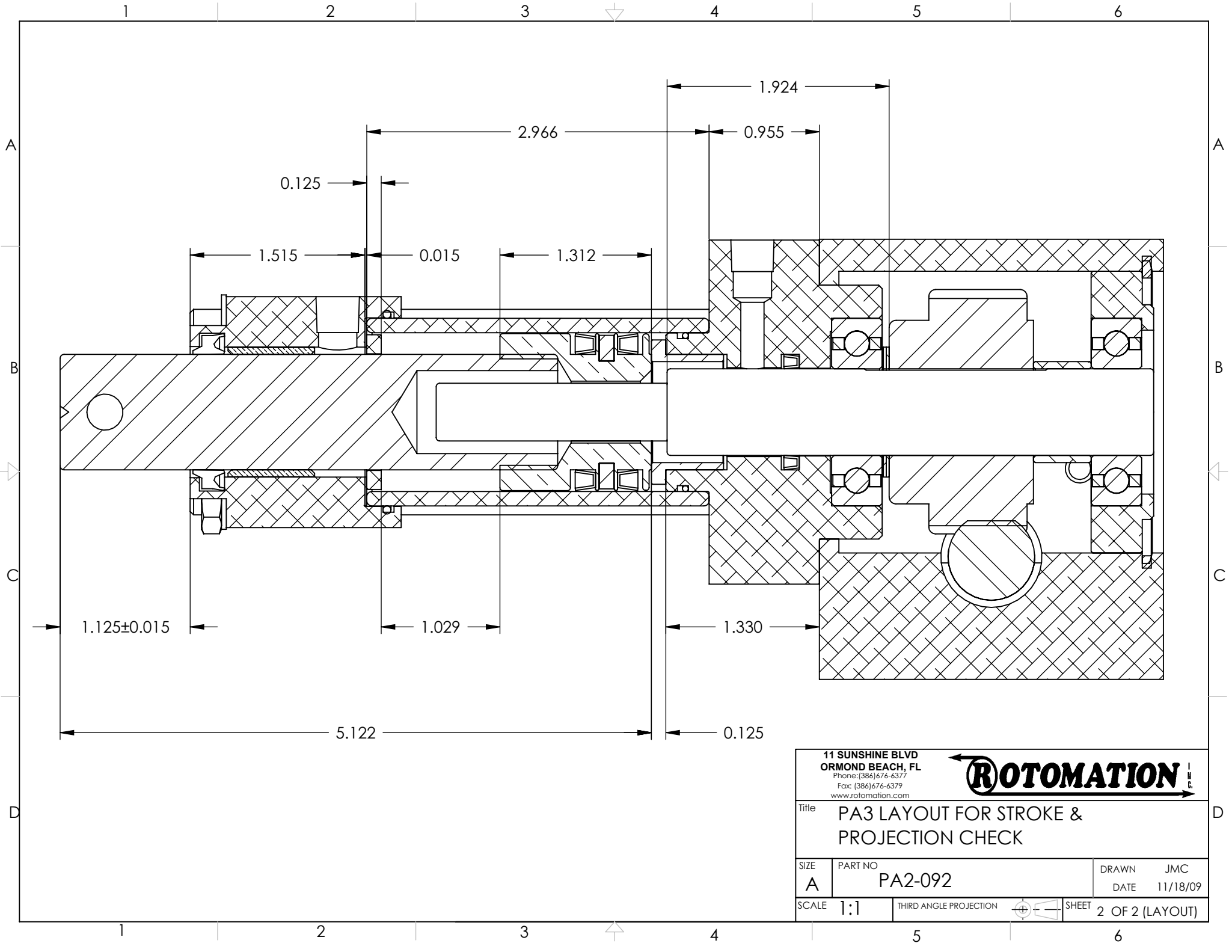

11 SUNSHINE BLVD
 ORMOND BEACH, FL
 Phone: (386) 676-6377
 Fax: (386) 676-6379
 www.rotomation.com



Title PA3 LAYOUT FOR STROKE & PROJECTION CHECK			
SIZE A	PART NO PA2-092	DRAWN JMC	DATE 11/18/09
SCALE 1:1	THIRD ANGLE PROJECTION	SHEET 2 OF 2 (LAYOUT)	