

X32 INDEXING ACTUATOR

ALL DIMENSIONS IN INCHES

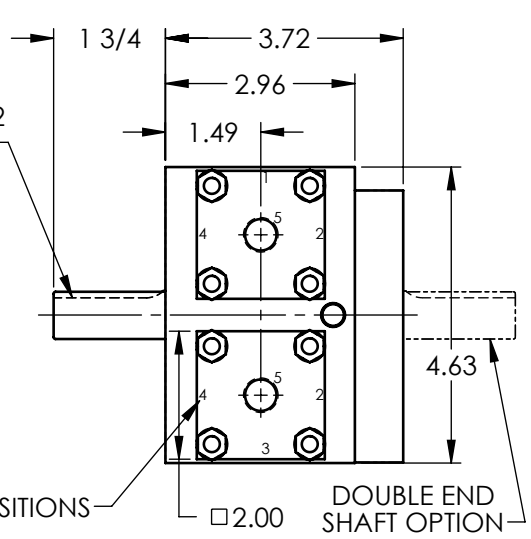
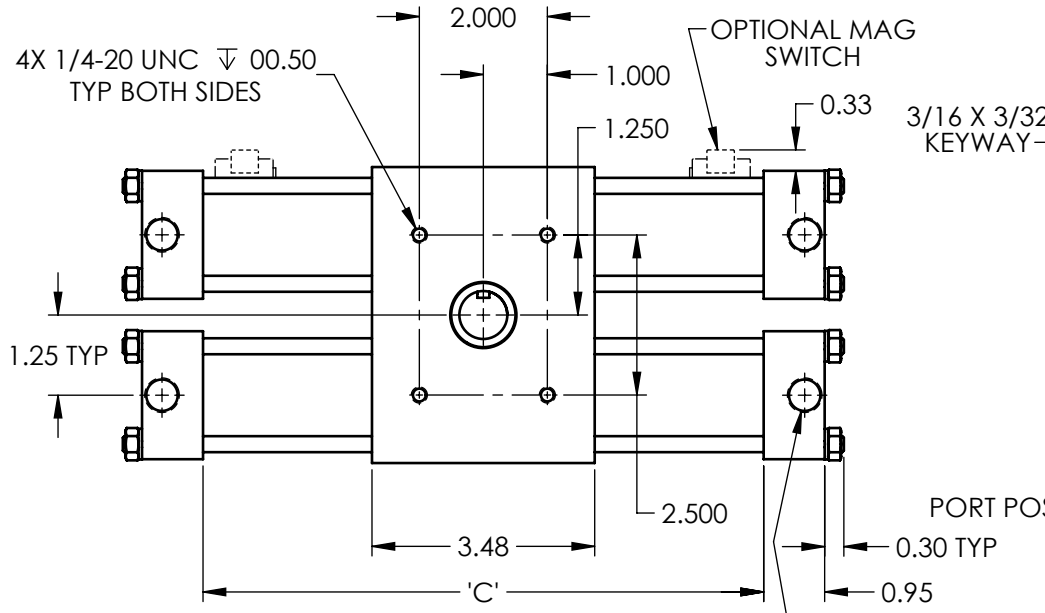

FRONT VIEW

END VIEW

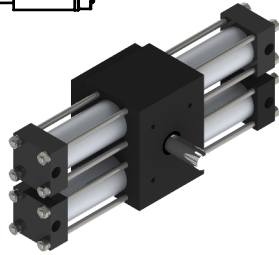
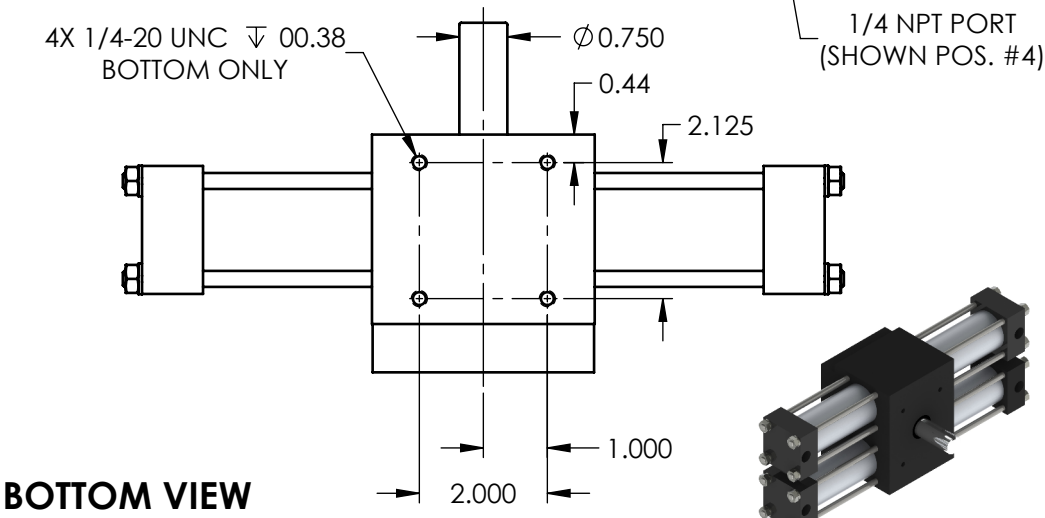

BOTTOM VIEW

'C' DIMENSION		
ROTATION +/-0.2 (degrees)	STANDARD (inches)	'G', 'R' OR 'S' OPTION (inches)
12	4.31	6.32
15	4.41	6.37
18	4.52	6.42
22.5	4.68	6.5
30	4.94	6.63
36	5.15	6.74
45	5.46	6.9
60	5.99	7.16
72	6.4	7.4
90	7.03	8.03
120	8.08	9.08
180	10.17	11.17
360	16.46	17.46

OPTIONS: ADD TO 'C' DIM. PER SIDE		
'Q' OPTION	'Q' & 'A' OPTION	'HP', 'A', OR 'K' OPTION
0.06	N/A	N/A

RATINGS	
Torque Factor (in-lb/psi)	2.98
Bore Diameter (in)	1 3/8
Max. Working Pressure (psi)	60
Backlash @ End of Stroke (degrees)	0
Max. Bearing Axial Load (lb)	257
Max. Bearing Radial Load (lb)	1030
Shaft Bearing Spacing (in)	2.36
Max. Reverse Torque (in lb)	98
Max. Kinetic Energy (in lb)	8.9
Displacement (in ³ /deg.)	0.052
Weight: 180 deg. basic unit (lb)	9.6
Operating Temp. Range (°F):	Basic 0 to 180 'G', 'R', 'S', or 'Q' OPTION 0 to 160

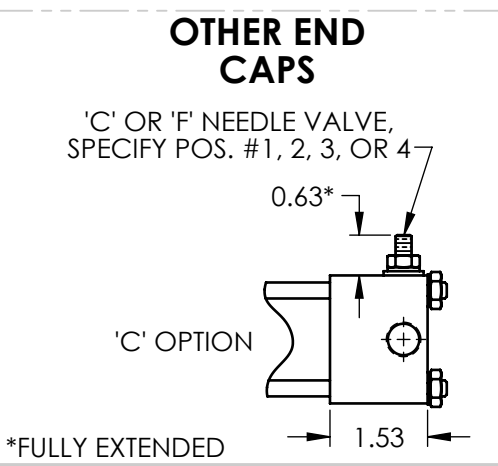

SHAFT KEYWAY REFERENCE POSITION (R.P.)		
INDEXER ROTATION (degrees)	KEYWAY REFERENCE POSITION (O'clock)	(degrees)
30	11:30	345
60	9:00	270
120	6:00	180
All others	12:00	0
REFERENCE POSITION ACCURACY		±2.0°
'KL' OPTION (HIGH ACCURACY R.P.)		±0.2°

Note: 'KL' option not available on 15, 18, and 22.5 degrees units.

X32 ACTUATOR OPTIONS

EXTENDED PAWL SHAFT (SYMBOL: E)

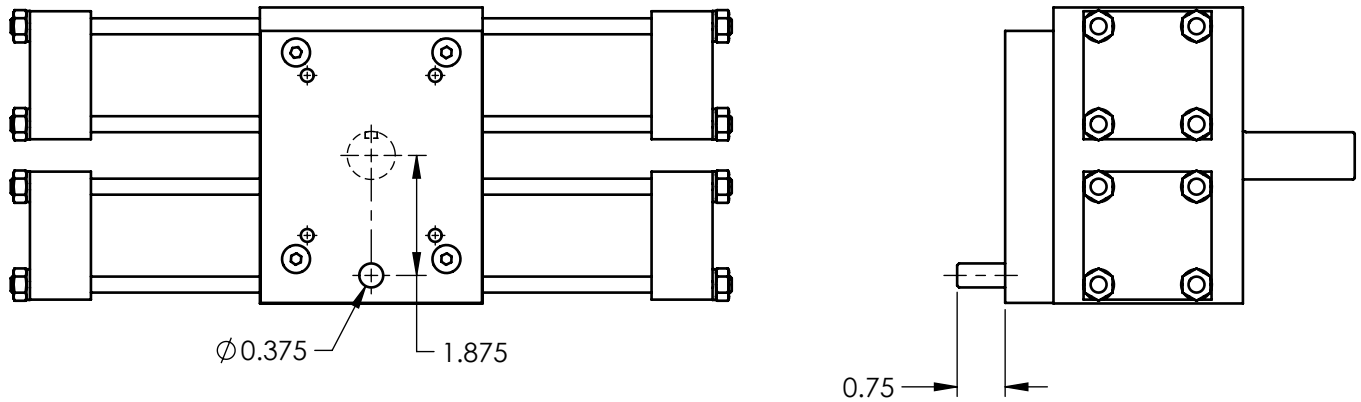

PAWL SHAFT MOVES 7° AT INDEX AND RESET (CAM DRIVEN AT RESET AND SPRING DRIVEN AT INDEX. USE NON-CONTACT SENSOR ONLY).

MOUNTING PLATE OPTIONS (SYMBOL: M, N, OR P)

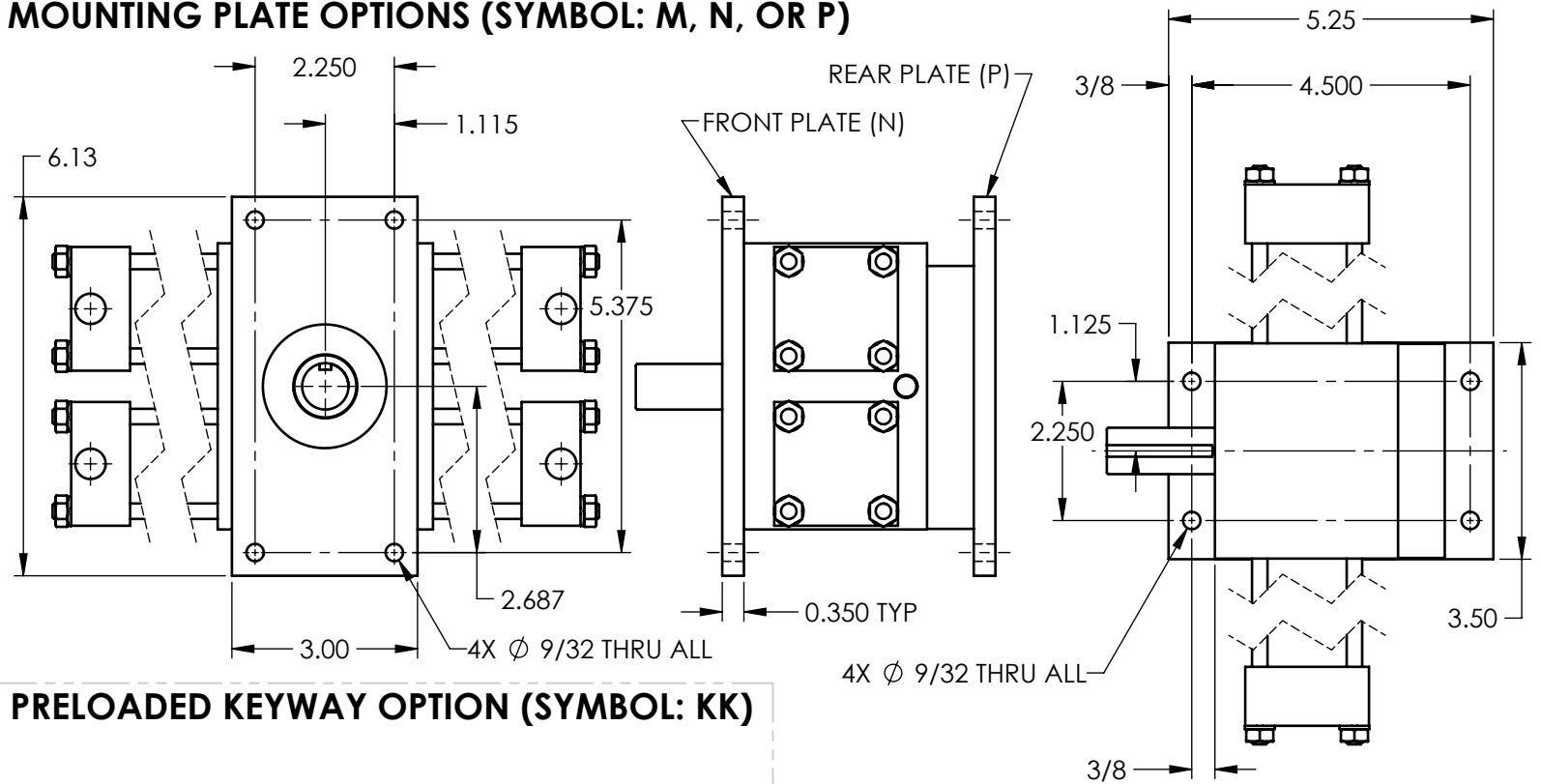

PRELOADED KEYWAY OPTION (SYMBOL: KK)

