

REAR VIEW
BEARING PLATE & BALL BEARING REMOVED
CCW INDEXER SHOWN IN DRIVE POSITION

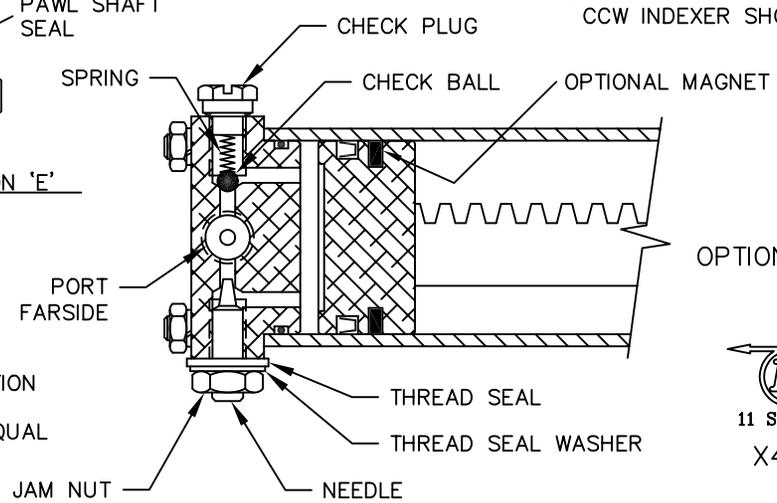

OPTIONAL FLOW CONTROL

- NOTES:**
1. 90° INDEXER SHOWN, OTHERS SIMILAR EXCEPT FOR RATCHET, CYLINDER & RACK LENGTH.
 2. ORDER PARTS BY PART NAME AND COMPLETE UNIT SPECIFICATION NUMBER OR SERIAL NUMBER.
 3. THIS SKETCH APPLIES TO UNITS SOLD WITH SERIAL NUMBER EQUAL TO OR HIGHER THAN 29806 FOR CLOCKWISE AND 30363 FOR COUNTER CLOCKWISE.